

(W4324)

HAFCO BP-420

16" Heavy Duty Band Saw

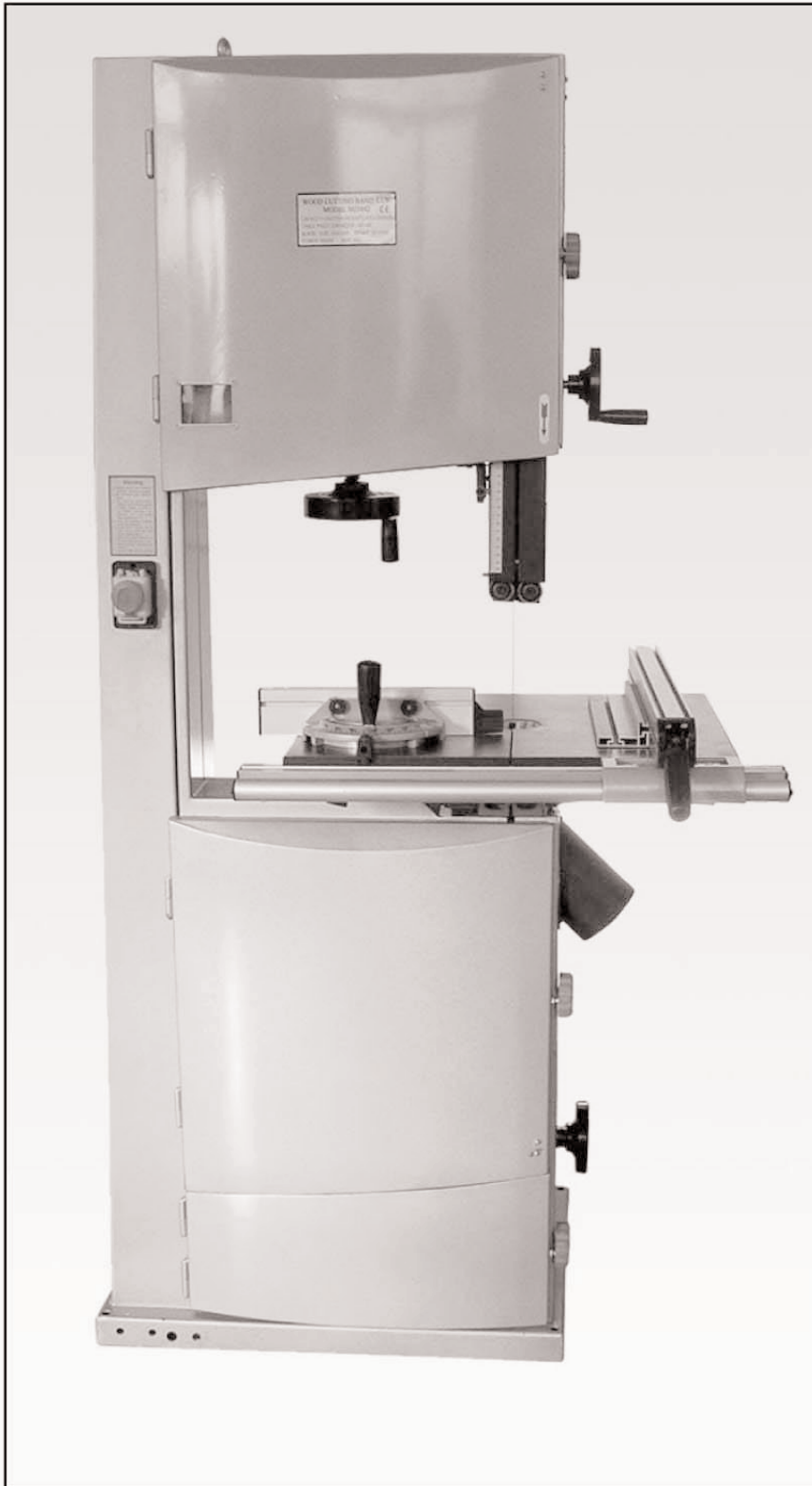

18" Heavy Duty Band Saw

1 Contents

1. Contents	P1
2. Please read first	P1
3. Specification	P1
4. Safety	P2
4.1 General safety instructions	P2
4.2 Specific safety instructions for band saw	P4
4.3 Symbols used throughout these instructions	P4
5. Unpacking	P4
6. Components & controls	P5
7. Assembly	P6
7.1 Initial assembly	P6
7.2 Setting instructions	P6
7.3 No volts emergency stop switch	P8
8. Operating	P9
8.1 Operating instructions	P9
8.2 Using the mitre gauge	P9
8.3 Tilting the table to perform bevel cuts	P9
8.4 Making freehand and radius cuts	P9
9. Adjustment & maintenance	P10
9.1 Changing the blade speed	P10
9.2 Replace the drive belt	P10
9.3 Changing the blade	P10
9.4 Maintenance	P10
10. Wiring diagram	P11
11. Troubleshooting	P12
12. Diagram & partslist	P13

2 Please Read First

WARNING!

When using electric tools basic safety precautions should always be followed to reduce the risk of fire, electric shock and personal injury including the following.

- Read these instructions before attempting to operate this product and save these Instructions.
- If you notice transport damage while unpacking, notify your supplier immediately. Do not operate the saw!
- Dispose of the packing in an environmentally friendly manner. Take to a proper collecting point.
- Keep these instructions for reference on any issues you may be uncertain about.

ATTENTION:



FOR YOUR OWN SAFETY: READ AND UNDERSTAND THE OWNER'S MANUAL BEFORE OPERATING MACHINE.

1. Set up the saw on a firm, level, non-slip, vibration-free base. Keep the site free of tripping hazards. Ensure adequate lighting conditions.
2. Do not wear loose fitting clothes, remove rings, wristwatch and bracelets. Tie back long hair.
3. Wear safety goggles and face shield if operation is dusty. Wear ear defenders.
4. Do not use the saw in a moist or wet environment, or in the vicinity of combustible liquids and gases.
5. The saw must only be operated with all correctly mounted guards.
6. Never use cracked or distorted saw blades. Only use sharp saw blades.
7. Use a pushing stick when rip sawing narrow work-piece.

3 Specification

Motor power	220V~50Hz, 2.2KW	
Throat width	mm	465
Sawblade length	mm	3607
Sawblade width	mm	6-37
Worktable tilt		-10 ^o ~ 45 ^o
Worktable size	mm	630x480
Sawblade speed	m/sec	7 or 14
Max. cutting depth	mm	280
Table height	mm	1000
Weight	Kg	162/180

4 Safety

4.1 General safety instructions

Before attempting to operate this machine, it is important that you read, understand and follow these instructions very carefully. They are designed for the safety of yourself and others ensuring a long and trouble free service life from your machine.

Safe Operation

Know Your Power Tool

It is important that you read and understand your instruction manual and any label attached to the power tool. Learn its applications as well as its limitations and the potential hazards associated with this power tool.

Work Area

Cluttered benches and work areas invite accidents. Workbenches should be kept tidy. Floors should be kept clean and free from rubbish. Special care should be taken where the floor is slippery due to sawdust or wax.

Work Environment

Do not expose your power tools to rain, or use in damp or wet locations. Keep the work area well lit. Do not use power tools in areas where there is a risk of explosion or fire from combustible materials, flammable liquids, paint, varnish, petrol etc. flammable gases and dust of an explosive nature. As a precaution it is recommended that you consult an expert on a suitable fire extinguisher and its use.

Guard Against Electric Shock

Avoid body contact with earthed or grounded surfaces (e.g. pipes, radiators, ranges, and refrigerators).

Beware Children and Pets

Children and pets should be kept out of the work area. Children should not be allowed to touch or operate machinery or touch extension cords. All power tools should be kept out of the reach of children, preferably stored or locked in a secure cabinet or room when not in use.

Do Not Force the Power Tool

The power tool will do a better and safer job and give you much better service if it is used at the rate for which it was designed.

Use the right tool

Select the right tool for the job. Do not use a tool for a job for which it was not designed. Do not force a small tool to do the job of a heavy-duty tool. Do not use tools for purposes not intended; for example do not use a circular saw to cut tree limbs or logs.

Personal safety

Clothing

Do not wear loose clothing, jewellery or anything that could get caught in moving machinery.

Hair

Long hair should be tied back or contained in a protective covering.

Eye Protection

The use of safety goggles is a mandatory requirement (normal glasses are not sufficient for eye protection). Prescription spectacles do not have safety lenses.

Ear Protection

Ear protection is advised during periods of extended operation.

Footwear

Where there is a risk of heavy objects damaging feet or if there is a risk of slipping on wet or slippery floors suitable non-slip safety footwear should be worn.

Head Protection

Where there is a risk of falling objects or hitting your head on protruding or low level obstructions a hard hat should be worn.

Respiratory Protection

When the machining operation creates dust, wear dust mask. When machining concrete, man made fibre boards, especially MDF (Medium Density Fibre Board) the resin used in these materials can be hazardous to your health. Use an approved face mask with replaceable filter.

Dust Extraction Equipment

If the machine is fitted with dust extraction and collection facilities ensure that these are properly connected and used.

Do Not Abuse the Power Cord

Never yank or pull on the power cord to disconnect it from the mains supply socket. Never carry your power

tool by its power cord. Keep the power cord away from heat, oil, solvents and sharp edges. If the power cord becomes damaged have it replaced by an authorised service facility.

Secure the Work Piece

Wherever possible secure the work piece using clamps or a vice. It is safer than using your hand and leaves both hands free to control the power tool.

Do Not Over-reach

Do not over-reach, keep proper footing and maintain your balance at all times.

Maintain Tools with Care

Keep cutting tools sharp and clean for better and safer performance.

Follow the instructions for lubricating and changing accessories.

Check the tool power cord periodically and if damaged have it replaced by an authorised service facility.

Inspect extension cords periodically and if damaged replace it.

Keep handles dry, clean and free from oil and grease.

Ensure that ventilation slots are kept clean and free from dust at all times. Blocked ventilation slots can cause overheating and damage to the motor.

Disconnect Power Tools

Ensure that power tools are disconnected from the mains supply when not in use, before servicing, lubricating or making adjustments and when changing accessories such as blades, bits and cutters.

Remove Adjusting Keys and Wrenches

Form the habit of always checking to see that keys and adjusting wrenches are removed from the power tool before turning it on.

Avoid Unintentional Starting

Ensure that the switch is in the OFF position before plugging the power tool into the mains supply.

Extension Cords and Reels

DO NOT use 2 core extension cords or reels on power tools with an earth path. Always use a 3 core extension cord or reel with the earth core connected to earth.

When the power tool is to be used outdoors, use only extension cords intended for outdoor use and are so marked.

Always unwind any extension cords fully.

For extension cords upto 15 metres use a wire cross section of 1.5mm².

For extension cords over 15 metres but less than 40 metres use a wire cross section of 2.5mm².

Always replace a damaged extension cord before using it. Protect your extension cord from sharp objects, excessive heat and damp or wet locations.

Stay Alert

Watch what you are doing, use common sense, and do not operate the power tool when you are tired, if taking medication that causes drowsiness, when having consumed alcohol or taken drugs.

Check Damaged Parts

Before using the power tool it should be carefully checked to determine that it will operate properly and perform its intended function.

Check for the correct alignment of moving parts ensuring they do not bind. Check for broken or missing parts and have them replaced or repaired at an authorised service centre. If the power tool requires mounting make sure it is securely attached to a suitable work bench. Check any other condition that may affect the operation of the power tool.

A guard or any other part of the power tool that is damaged should be properly repaired or replaced by an authorised service centre unless otherwise indicated in this instruction manual.

Any switch that does not operate correctly must be replaced by an authorised service centre.

Do not use the power tool if the ON/OFF switch does not turn the power tool ON and OFF.

Warning!

Do not attempt to modify the power tool in any way. The use of any attachment or accessory other than those recommended in this instruction manual could result in damage to the power tool and injury to the operator.

Have your power tool repaired by a qualified person.

This electric power tool complies with national and international standards and safety requirements.

Repairs should only be carried out by qualified persons using original spare parts. Failure to do so may result in considerable danger to the user.

Protect Furnishings

If using the power tool inside your house protect furnishings and floors with a suitable dust sheet.

Fire Precautions

When using certain power tools inside your house or workshop general fire precautions should be observed. As a precaution it is recommended that an expert is consulted on obtaining and using a suitable fire extinguisher.

4.2 Specific safety instructions for band saw



WARNING!

Some wood and wood type products, especially MDF (Medium Density Fibreboard) can produce dust that can be hazardous to your health. We recommend the use of an approved face mask with replaceable filters when using this machine in addition to using the dust extraction facility.

Approved safety glasses or goggles and ear defenders must be worn when using the power tool for prolonged periods.

Ensure that power tools are disconnected from the mains supply when not in use, before servicing, lubricating or making adjustments and when changing accessories such as blades.

Ensure that the band saw is securely fastened to its base and wherever possible secure the base to the floor. When selecting a location for the band saw consideration needs to be given to the size of material to be cut and the area around the BandSaw.

Do Not attempt to use for wet cutting operations a fatal electric shock could occur. This machine is to be used for dry cutting only.

Do Not over tension the drive belt. The drive belt will last longer if the tension is released after each use.

Do Not allow sawdust to build up around the motor or inside the machine. A build up of sawdust is a fire hazard.

Do Not stop the blade by forcing the work piece or by using sideways pressure.

Keep Guards in place and in good working order.

Always ensure that the blade guide rollers are set correctly.

Do Not start the machine with the blade in contact with the work piece.

Check the work piece for any protruding nails, screw heads or anything that could damage the blade.

Do Not attempt to modify the machine or its accessories in any way.

Do Not use excessive force when feeding the work piece to the blade. Feeding the work piece gradually will reduce wear on the machine and blade increasing its efficiency and operating life.

Blade Safety

Use only blades that are recommended by the manufacturer.

Do Not use blades that are deformed or have missing teeth. This is highly dangerous and could result in a serious accident to the operator and bystanders as well as damaging the machine.

Only use blades that are recommended by the supplier and that are in good condition.

Ensure that the directional arrow, if marked on the blade corresponds with the rotational direction of the motor. The teeth of the blade should always point downward when viewed from the front of the saw.

Always release the blade tension, when the machine is not in use.

Always wear gloves and eye protection when fitting or removing blades.

Always uncoil blades in spacious areas, away from other people.

Always keep looped blades secure with tie wires.

Always keep fingers away from moving blades.

4.3 Symbols used throughout these instructions



Danger!

Indicates risk of personal injury or severe material damage.



Risk of electric shock!

Risk of personal injury by electric shock.



Drawing-in/trapping hazard!

Risk of personal injury by body parts or clothing being drawn into the rotating saw blades.



Caution!

Risk of material damage.



Note:

Supplementary information.

5 Unpacking



Note: make sure all items are accounted for before discarding any packaging material.



Warning: to avoid injury, if any parts are missing, do not attempt to assemble the machine, do not plug in the power cord, do not turn the switch on until missing parts are obtained and installed correctly.

6 Components & Controls

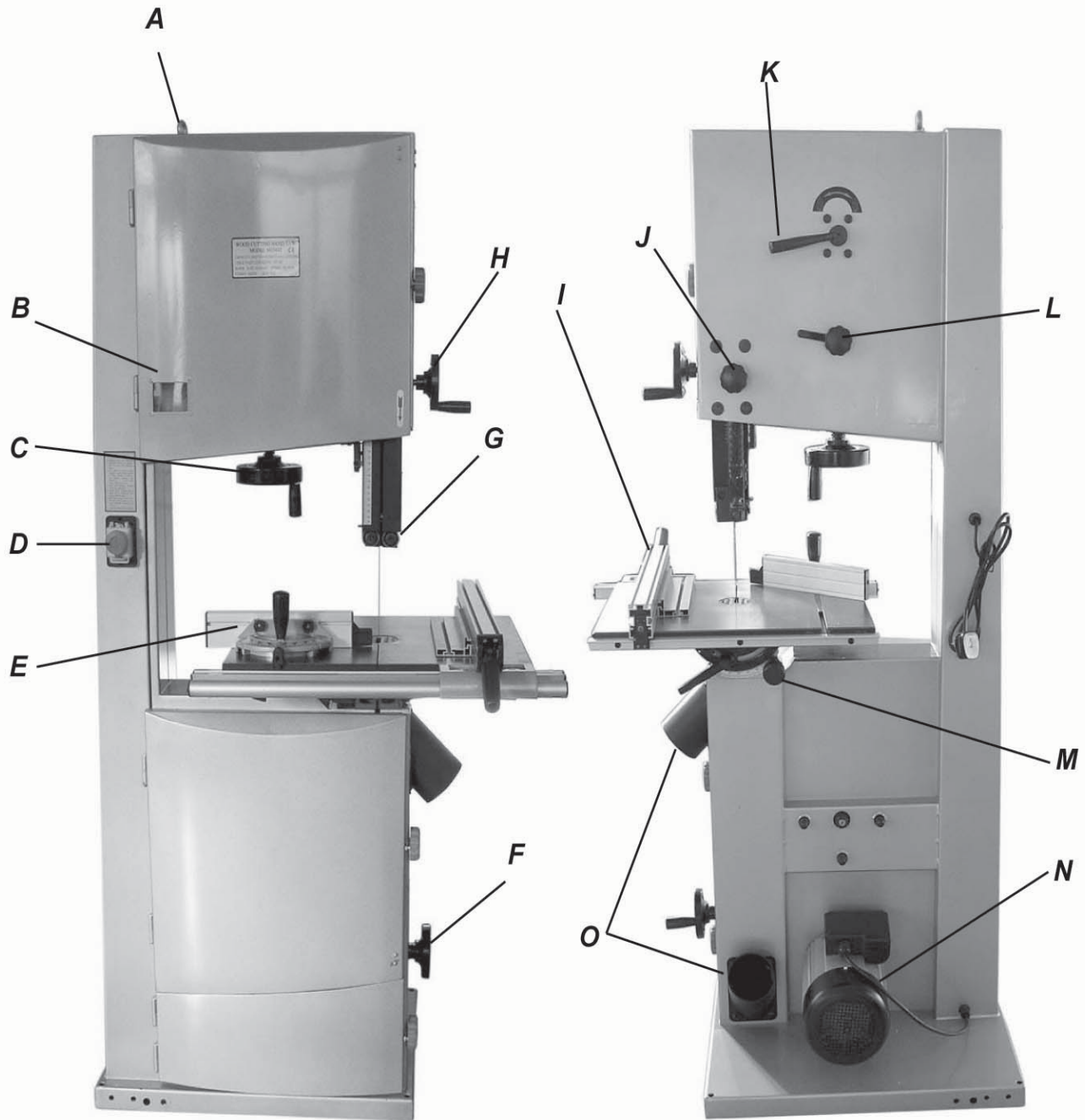

A. Hang Up Ring
B. Tension Indicator Window
C. Blade Tension Handwheel
D. Main Switch
E. Mitre Gauge
F. Belt Tension Handwheel
G. Blade Guide
H. Guide Post Handwheel

I. Rip Fence
J. Cut Depth Lock Knob
K. Quick Release Lever
L. Blade Tracking Knob
M. Table Tilting Knob
N. Motor
O. 4" Dust Ports

7 Assembly

7.1 Initial Assembly

This machine is supplied partly assembled. Prior to use, the following items to be fitted. Bandsaw Table, Rip Fence Guide, Guide Post Handwheel, Belt Tension Handwheel and Dust Port.

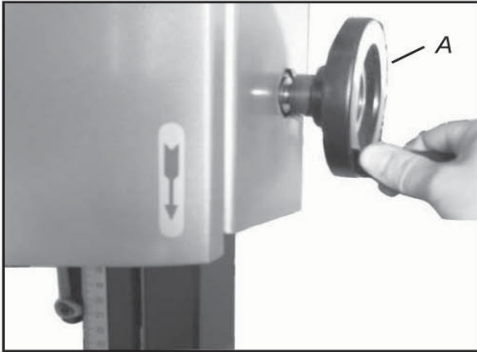

Fitting the guide post handwheel

Attach the guide post handwheel (A) to the shaft of worm gear with the M6x12 set screw.

Fitting the belt tension handwheel

Attach the belt tension handwheel (B) to the thread rod with the M6x12 set screw.

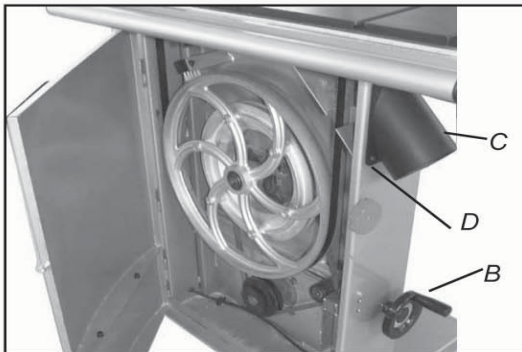

Fitting the upper dust port

Fit the upper dust port (C) to the side of lower wheel housing. Tighten 4 M5x16 (D) pan head screw (washers and nuts inside the housing).

Fitting the table

Fit the table onto the table trunnion ensuring that the securing bolt is placed through the hole in the trunnion. Secure the table in place with 4-M8x16 (E) hex head bolts & 4-8mm washers.

Fit the rip fence guide

This instruction assumes that the blade is already fitted,

if not, go to the section headed " Replacing the bandsaw blade".

To fit the Rip Fence Guide (F) attach it to the front edge of the table with the four winged screws and washers (G) supplied. This will be adjusted later.



7.2 Setting Instructions

Warning! Before carrying out any maintenance or adjustments the machine must be disconnected from the power supply.

Setting up the table

Place a suitable set square against the table and the blade.

Loosen the table securing lock lever and adjust the table until it is at a right angle to the blade. Resecure the table. If necessary adjust the tilt scale (H) or the table stop screw (I) underneath the table.

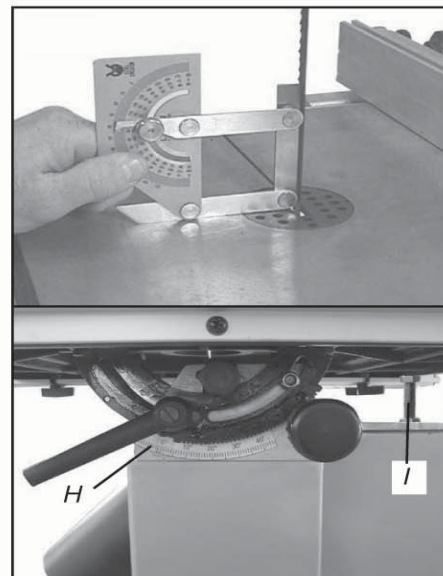

Setting up the blade tension & tracking

With the power supply disconnected, set the blade tension with the blade tension handwheel (J). Rotating the wheel in a clockwise direction will decrease the blade tension and anti clockwise will increase the tension. The blade is at the correct tension if it can be moved approximately 10 mm sideways with moderate hand pressure .
Tension the blade until the tension readings corresponds to the width blade you are using through the tension indicator window.

Dairly run you can through the blabe tension window to check the tension of blade.

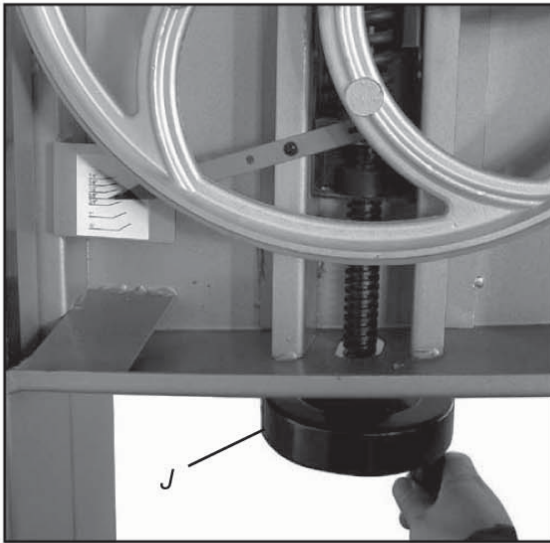

Tracking the saw blade

Firstly, make sure the upper and lower blade guides are adjusted away from the blade and the tension scale reading corresponds to the width blade you are using. Then loosen the lock lever (K) by turning it counterclockwise and turn the blade tracking knob (L) clockwise /counterclockwise while turning the upper wheel by hand at least three rotations until the blade tracks centered on the wheel.
Finally, tighten the lock lever and close the doors.

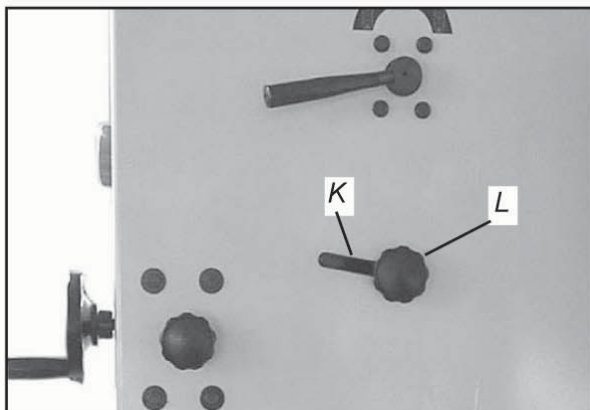

Dairly run you can through the blabe tracking window to check the tracking of blade.

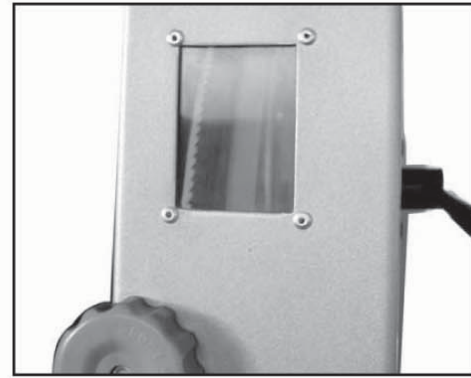

Setting up the blade guides

The blade guides minimise blade movement while making a cut.
The upper guide bearings and lower guide posts should be 0.5mm away from the sides of the blade.
Position the rear thrust bearings approximately 3mm behind the blade. This will only come into contact with the blade as the work piece is cut.

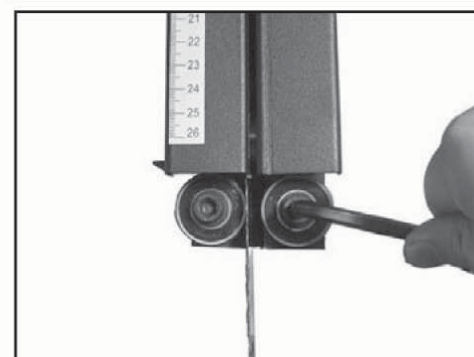
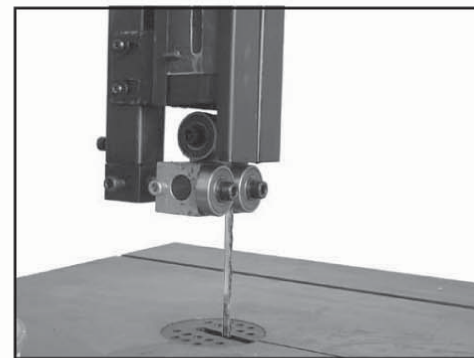

With the power supply disconnected rotate the blade wheel by hand ensuring that the blade does not catch on the guides.

NB: When using narrow blades (6mm) the lower rear blade support bearing needs to be in contact with the blade.

When wider blades are fitted it will be necessary to move the blade guide assemblies backwards to ensure the blade guides are always in the correct position.

To move the upper blade guide loosen the socket screw(M), slide the rod of upper guide to guide position is achieved.

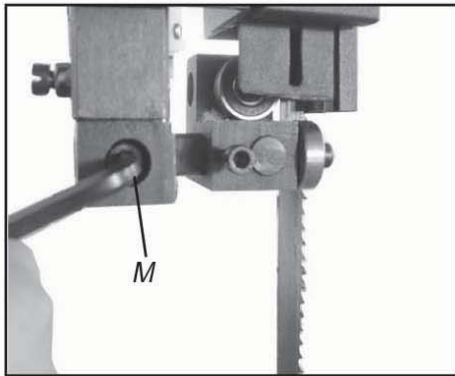

The lower blade guide is moved by loosening the socket screw(N), and turn the rear guide knob(O) to guide position is achieved.

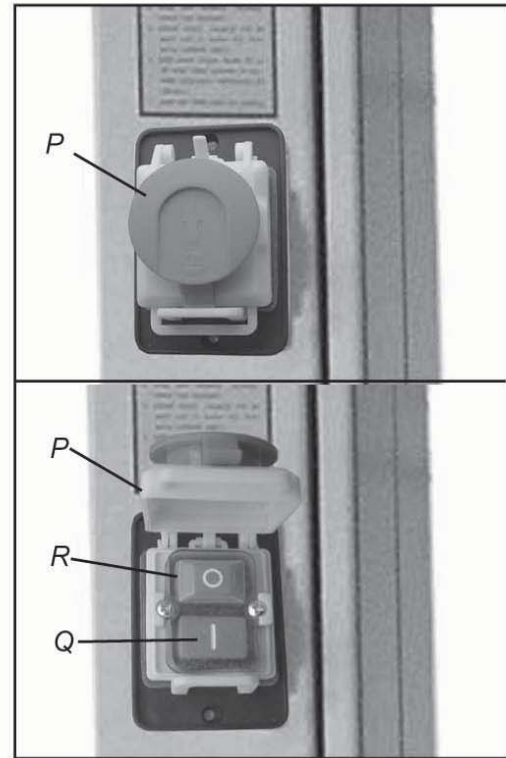
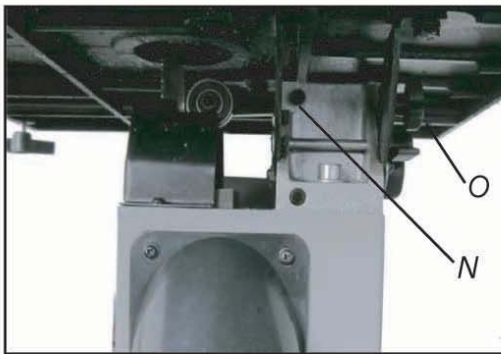

emergency stop cover(P) and press green the ON button(Q). To stop the machine, press the red OFF button(R). In the event of an emergency, hit the emergency stop cover(P), this will switch the machine OFF and will mechanically lock the emergency stop cover in place preventing the machine from being switched on until the mechanical lock has been released. To release the mechanical lock depress the emergency button and slide it upwards.

7.3 No Volts Emergency Stop Switch

This machine is fitted with a "No Volts Switch". In the event of a mains power failure or if the mains plug is removed from the mains supply socket before the machine is switched off. The machine will not re-start without warning when the mains supply is restored or the mains plug is re-connected to the mains supply, until the machine is switched ON at the ON/OFF switch fitted to the machine. The switch is also fitted with an emergency stop cover. To start the machine, lift the

8 Operating

8.1 Operating instructions

The upper blade guide assembly must be lowered to just clear of the work piece. To lower the assembly loosen the cut depth lock knob(T) and turn the guide post hand-wheel(U) to slide the upper guide assembly down. Re-secure the cut depth lock knob(T).

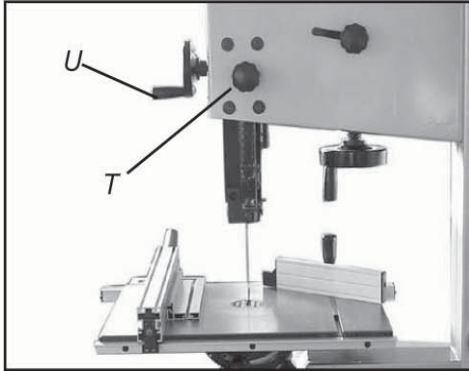

Set the rip fence to the desired width (ensure that the largest section of the material is against the fence).

Plan the cut before starting. Ensure that push sticks and other work aids are used when the work piece is too small to enable your hands to be kept clear of the blade. Before commencing a cut on a large work piece ensure that there is sufficient space around the saw for the movement of the piece. Also ensure that the piece is supported where necessary to avoid undue stress against the blade.

Allow the material to be cut at a steady even pace. A clear sign that the work piece is being forced to be cut too quickly is the motor changing pitch or slowing down.

8.2 Using the mitre gauge

Make a practice cut with the gauge in the 0° position then test the cut with a suitable set square. If adjustment is necessary loosen the screw that holds the "pointer" and move the pointer accordingly .

The mitre gauge can be used in either groove in the table. Set the desired angle on the mitre scale and make the cut securely holding the work piece to the mitre gauge.

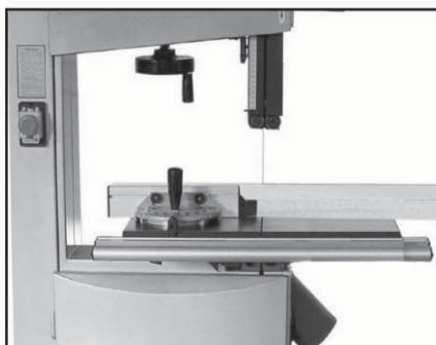

8.3 Tilting the table to perform bevel cuts

To use the table to perform a bevel cut, loosen the table trunnion locking lever(V) and turn the table tilt handle(W) to tilt the table over to the desired angle.

Re-secure the locking lever(V).

Compound mitre cuts can be made by using the mitre gauge in conjunction with the table tilting facility.

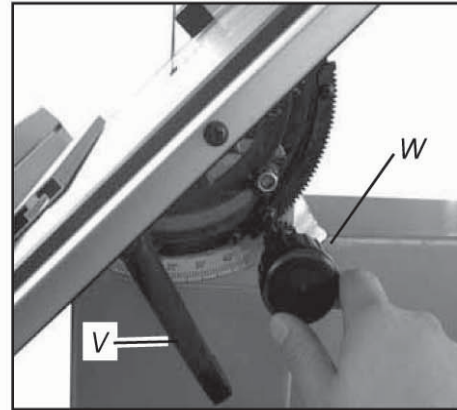

8.4 Making freehand and radius cuts

The general safety rules apply when making free hand cuts. It is advised that the rip fence is removed during these operations. The table below shows approximate radius that can be cut with which size of blade width.

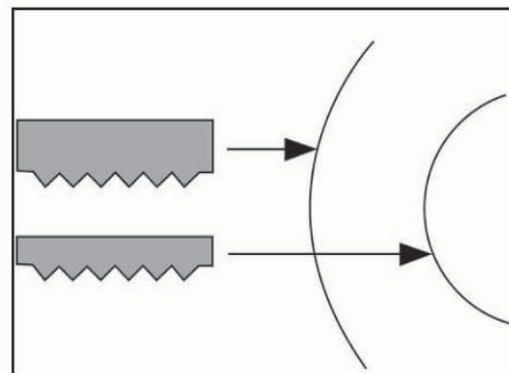

9 Adjustment & Maintenance

9.1 Changing the Blade Speed

 **Warning!** Before changing the speed always make sure the machine has been unplugged from the electrical supply.

To change the speed of the blade, open the lower blade wheel cover. Fully slacken the belt tension by using the belt tension handwheel (X). Slowly rotate the blade wheel by hand and at the same time ease the drive belt off the largest motor pulley onto the smallest motor pulley. Using the same procedure move the drive belt from the smaller drive wheel pulley onto the largest drive wheel pulley.

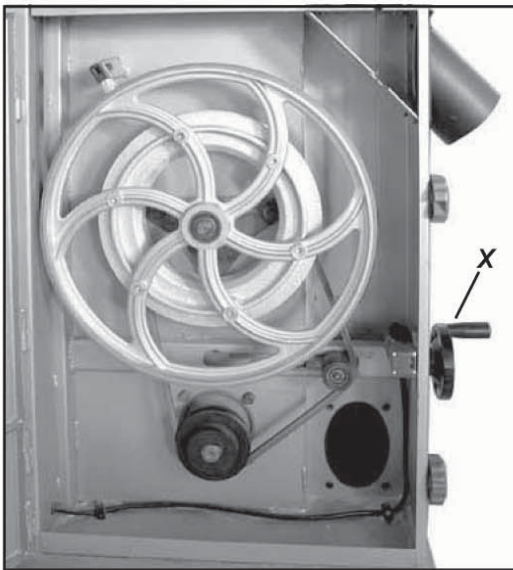

NB: The high blade speed is achieved when the drive belt is on the larger diameter drive pulley (motor).

9.2 Replacing the drive belt

Remove the blade (see changing the blade). Follow the procedure for changing the blade speed to release the belt tension. Carefully pull the belt off the machine, and replace the new belt over the drive blade wheel.

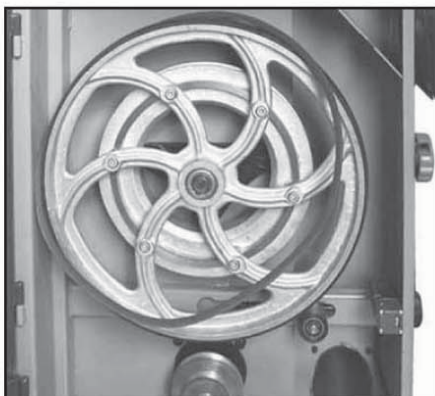

9.3 Changing the blade

 **Warning!** Unplug the machine from the electrical supply. This ensures that the bandsaw will not accidentally turn on if the ON/OFF switch is bumped.

Open both the upper and lower blade wheel covers. Remove the rip fence and guide from the table. Release the blade tension by rotating the quick release lever (Y) clockwise. Remove the saw blade from the machine taking great care to avoid the sharp teeth.

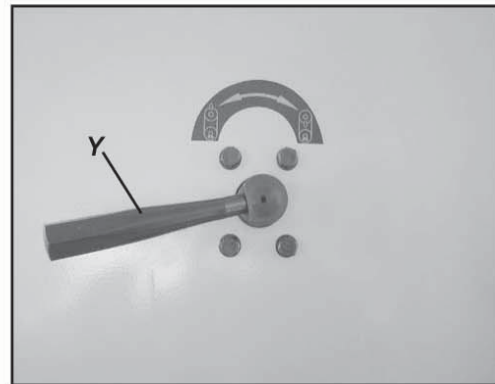

Caution: Because the blade is an endless loop it may spring and coil itself into smaller loops.

Replace the blade in the reverse manner ensuring that the teeth point downwards when viewed from the front of the machine.

Re-tension and track the blade in accordance with the pre operation instructions.

If necessary reset the blade guides in accordance with the pre operation instructions.

9.4 Maintenance

 **Caution!** Before cleaning or carrying out maintenance work, disconnect the machine from the power source (wall socket). Never use water or other liquids to clean the machine. Use a brush. Regular maintenance of the machine will prevent unnecessary problems.

Keep the table clean to ensure accurate cutting.

Keep the outside of the machine clean to ensure accurate operation of all moving parts and prevent excessive wear.

Keep the ventilation slots of the motor clean to prevent it from overheating.

Keep the inside (near the saw blade, etc.) clean to prevent accumulation of dust.

10 Wiring diagram



WARNING!

This machine must be grounded.

Replacement of the power supply cable should only be done by a qualified electrician.

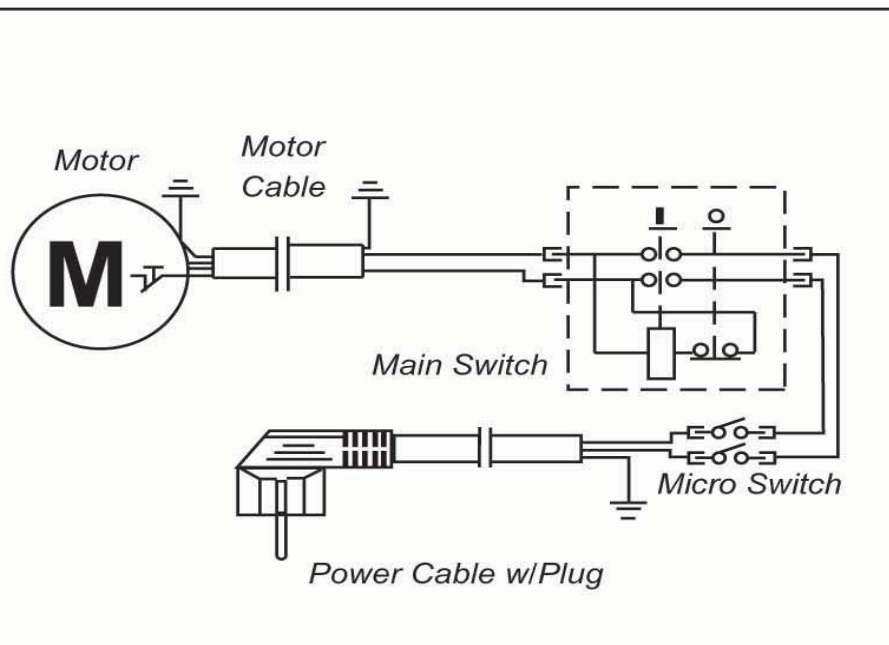

11 Troubleshooting



WARNING: FOR YOUR OWN SAFETY, ALWAYS TURN OFF AND UNPLUG THE MACHINE BEFORE CARRYING OUT ANY TROUBLESHOOTING.

TROUBLE	PROBABLE CAUSE	REMEDY
The machine does not work when switched on.	<ol style="list-style-type: none"> 1. No power supply. 2. Defective switch. 	<p>Check the cable for breakage. Contact your local dealer for repair.</p>
The blade does not move with the motor running.	<ol style="list-style-type: none"> 1. The quick release lever or blade tension handwheel has not been tightened. 2. The blade has come off one of the wheels. 3. The saw blade has broken. 4. The drive belt has snapped. 	<p>Switch off the motor, tighten the quick release lever or blade tension handwheel.</p> <p>Open the hinged door and check.</p> <p>Replace the blade. Replace the belt.</p>
The blade does not cut in a straight line.	<ol style="list-style-type: none"> 1. Fence for cutting not used. 2. Too fast feed rate. 3. The blade teeth are dull or damaged. 4. Blade guides not suitably adjusted. 	<p>Use a fence. Put light pressure on the workpiece & make sure the blade does not bend. Use a new blade.</p> <p>Adjust the blade guides (see the section on page 7).</p>
The blade does not cut, or cuts very slowly.	<ol style="list-style-type: none"> 1. The teeth are dull, caused by cutting hard material or long use. 2. The blade was mounted in the wrong direction. 	<p>Replace the blade, use a 6 T.P.I. blade for wood and soft materials. Use a 14 T.P.I. blade for harder materials. A 14 T.P.I. blade always cuts slower due to the finer teeth and the slower cutting performance. Fit the blade correctly.</p>
Sawdust builds up inside the machine.	<ol style="list-style-type: none"> 1. This is normal 	<p>Clean the machine regularly. Open the hinged door and remove the sawdust with a vacuum cleaner.</p>
Sawdust inside the motor housing.	<ol style="list-style-type: none"> 1. Excessive dust build-up on the machine exterior components. 	<p>Clean the ventilating slots of the motor with a vacuum cleaner. From time to time remove the sawdust to prevent it from being sucked into the housing</p>
The machine does not cut at 45 or 90 angles.	<ol style="list-style-type: none"> 1. The table is not at right angles to the blade. 2. The blade is dull or too much pressure was put on the workpiece. 	<p>Adjust the table.</p> <p>Replace the blade or put less pressure on the workpiece.</p>
The blade cannot be properly positioned on the blade wheels.	<ol style="list-style-type: none"> 1. The wheels are not in alignment. Defective bearing. 2. The blade tracking knob hasn't been properly adjusted. 3. Inferior blade. 	<p>Contact your local dealer for repair.</p> <p>Adjust the knob (see the section on page 6).</p> <p>Replace the blade.</p>

12 Diagram & Partslist

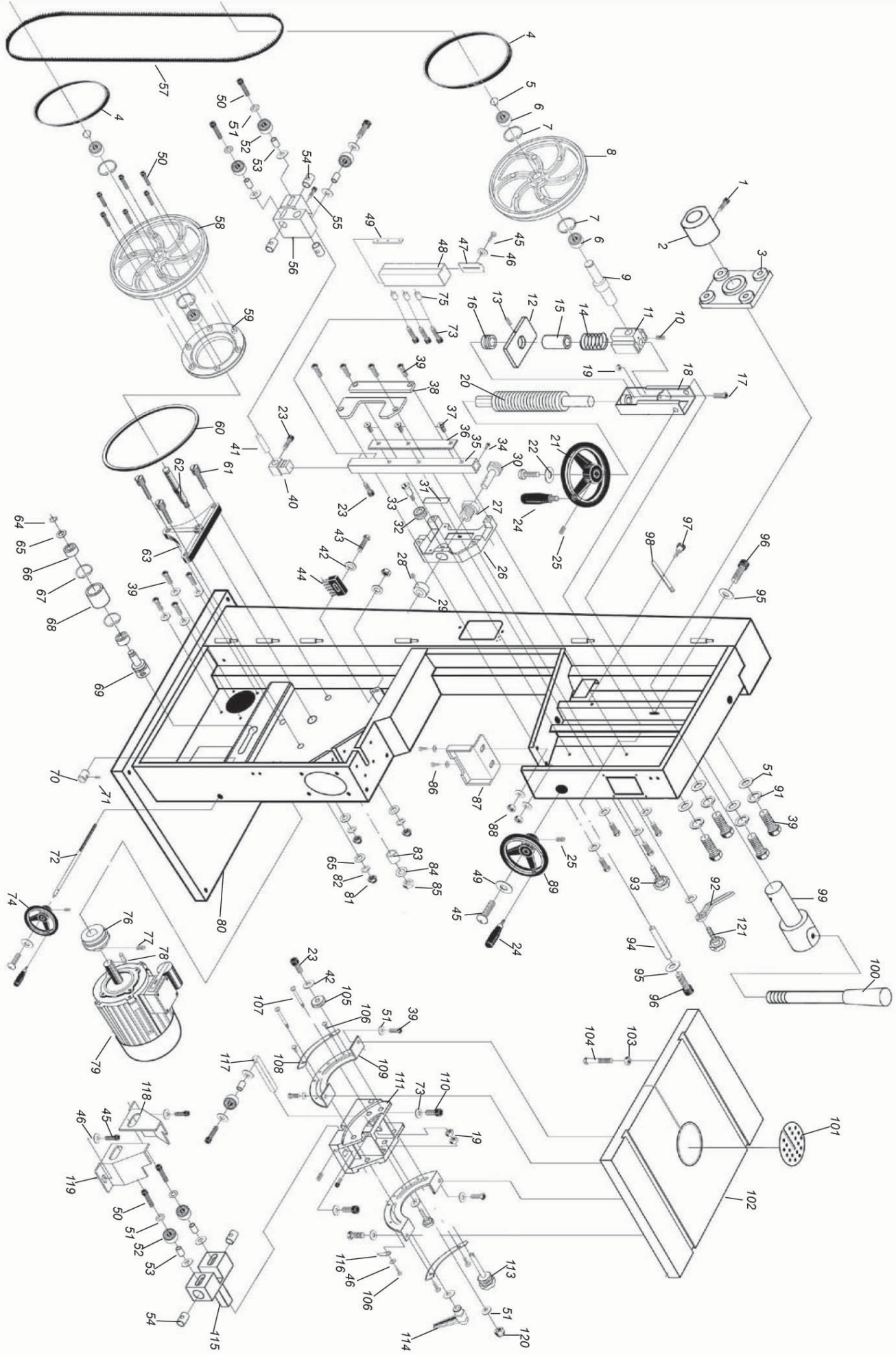

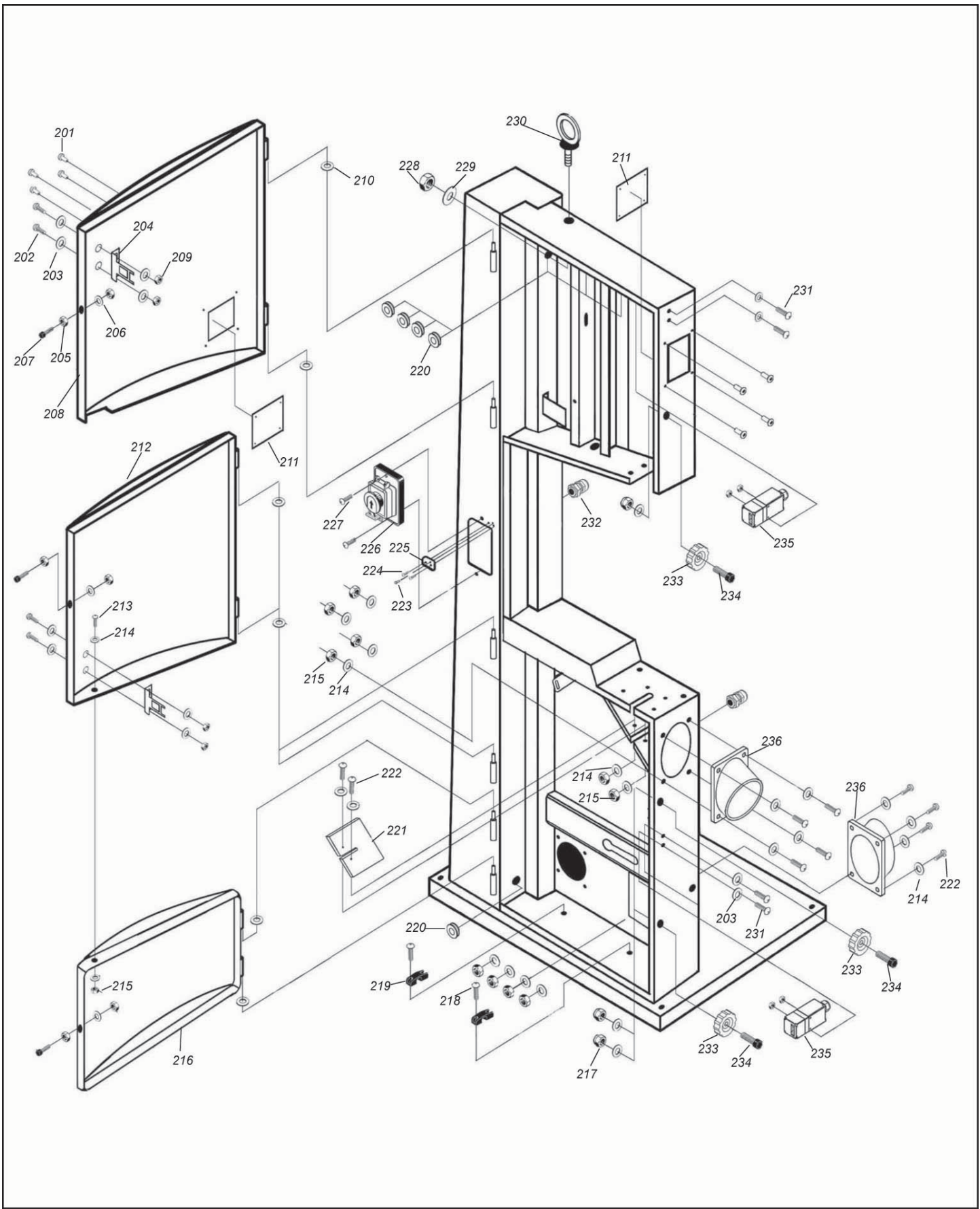

NO	DESCRIPTION	NO	DESCRIPTION
1	Allen bolt M6x20	46	Washer 5mm
2	Cam shaft	47	Sliding guard
3	Cam base	48	Safe guard, upper guide
4	Tyre	49	Bracket
5	Ring circle 20mm	50	Allen bolt M8x30
6	Bearing 80104	51	Washer 8mm
7	Ring circle 42mm	52	Bearing 80201
8	Upper wheel	53	Bush, bearing
9	Shaft, upper wheel	54	Nut, bearing
10	Screw set M6x10	55	Allen bolt M6x16
11	Mount, upper wheel	56	Guide base, upper guide
12	Indicator base	57	Saw blade
13	Pin roll 3x10	58	Lower wheel
14	Spring	59	Pulley drive
15	Spring seat	60	Belt "A"
16	Bearing, trust 8201	61	Dual thread screw
17	Hex screw M6x30	62	Shaft, lower wheel
18	Bracket, upper wheel	63	Bracket, lower wheel
19	Hex nut M6	64	Ring circle 12 mm
20	Thread, upper wheel	65	Washer 12mm
21	Hand wheel	66	Bearing 80101
22	Flat washer 6mm	67	Ring circle 28mm
23	Allen bolt M6x16	68	Tension pulley
24	Lever	69	Shaft, tension pulley
25	Screw set M6x12	70	Collar, tension rod
26	Mount, upper guide	71	Screw set M6x8
27	Thread tube	72	Thread , tension rod
28	Screw set M4x5	73	Allen bolt M5x30
29	Ring, worm	74	Handwheel, tension
30	Worm	75	Spacer
31	Insert, upper guide	76	Motor pulley
32	Gear, upper guide	77	Screw set m5x10
33	Thread, gear	78	Key flat
34	Allen bolt M5x10	79	Motor
35	Square tube, upper guide	80	Saw frame
36	Rack	81	Spring washer 12mm
37	Sunk head screw M5x10	82	Cap nut M12
38	Cover plate, upper guide	83	Bush, shaft lower wheel
39	Allen screw M8x16	84	Washer 16mm
40	Mount, upper guide	85	Hex nut M16
41	Shaft bearing, upper guide	86	Cross pan head screw M5x16
42	Flat washer 6mm	87	Pointer, mount
43	Hex screw M6x30	88	Hex nut M5
44	Brush	89	Hand wheel
45	Allen bolt M5x10	90	Cross pan head screw M6x10

<u>NO</u>	<u>DESCRIPTION</u>	<u>NO</u>	<u>DESCRIPTION</u>
91	Spring washer	107	Carriage bolt M8x80
92	Lock lever, wheel tilt	108	Rack, table trunnion
93	Lock, flower screw	109	Table trunnion, upper
94	Parallel pin	110	Allen bolt M10x30
95	Flat washer 8mm	111	Table trunnion, lower
96	Allen bolt M8x12	112	Flower screw, lower guide
97	Screw, indicator	113	Flower screw & shaft, lower guide
98	Indicator	114	Lock lever, table tilt
99	Lock cam	115	Guide base, lower guide
100	Lever, lock cam	116	Pointer, table tilt
101	Insert cut	117	Guide rod, bearing
102	Table	118	Guard left, lower guide
103	Hex nut M8	119	Guard right, lower guide
104	Hex screw M8x70	120	Lock nut M8
105	Tilt rack	121	Flower screw M8x50
106	Cross pan head screw M5x6		

<u>NO</u>	<u>DESCRIPTION</u>	<u>NO</u>	<u>DESCRIPTION</u>
201	Rivet	219	Clamp, cord
202	Cross pan head screw M4x10	220	Bush, cord
203	Washer 4 mm	221	Flat brush
204	Key, microswitch	222	Cross pan head screw M5x10
205	Hex nut M6	223	Pan head rivet 2x5
206	Washer 6mm	224	Cross pan head screw M4x6
207	Allen bolt M6x20	225	Grounding terminal
208	Door upper	226	Power switch
209	Hex nut M4	227	Cross pan head screw M4x12
210	Copper ring	228	Hex nut M10
211	View window	229	Washer 10mm
212	Door Middle	230	Ring, lift up
213	Cross pan head screw M5x12	231	Cross pan head screw M4x4
214	Washer 5mm	232	Strain relief
215	Hex nut M5	233	Door lock
216	Door lower	234	Allen bolt M6x22
217	Lock nut M6	235	Microswitch
218	Cross pan head screw M5x10	236	Suction connection

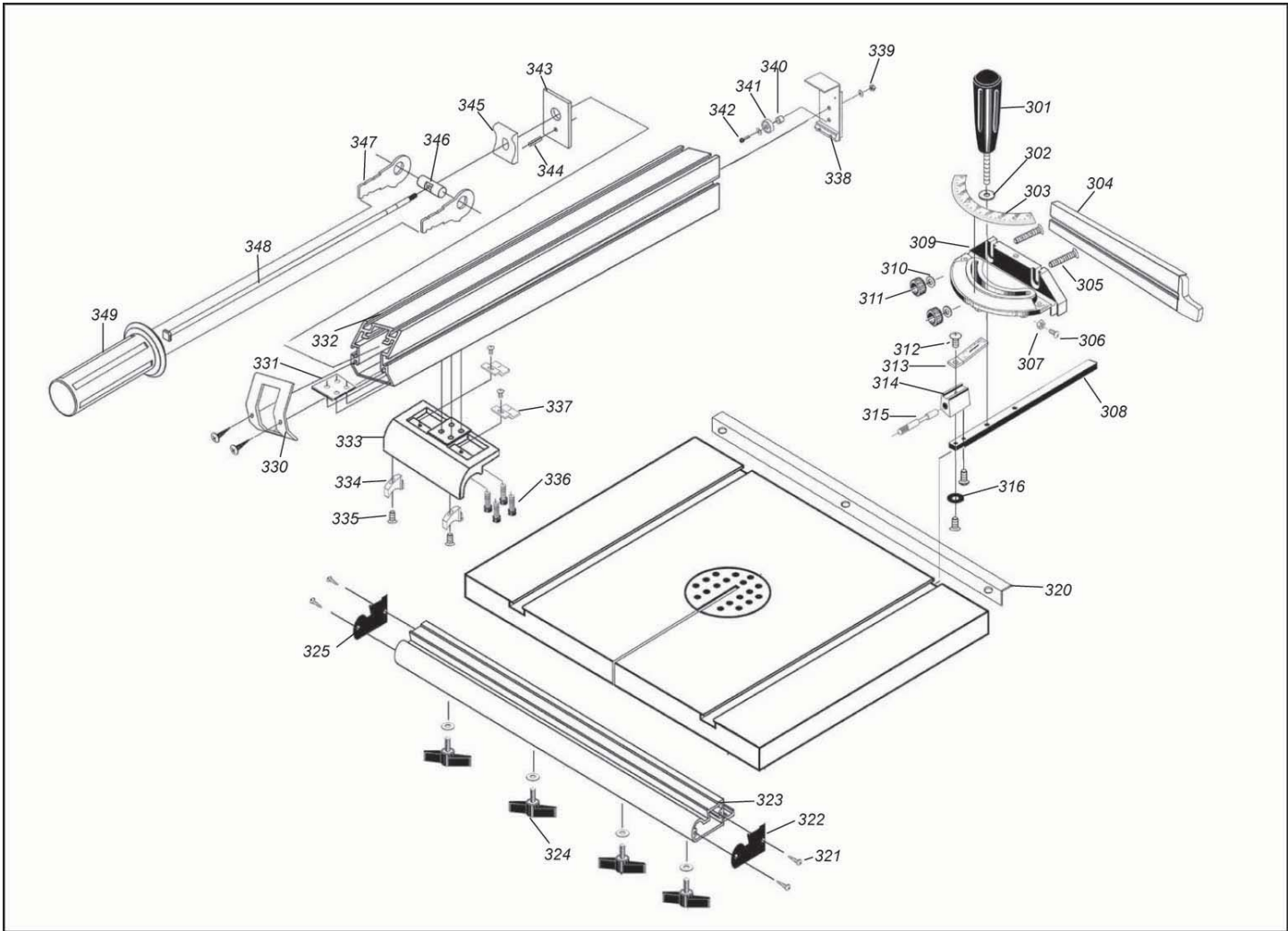

NO	DESCRIPTION	NO	DESCRIPTION
301	Mitre gauge knob	330	Front plat, fence
302	Washer 8mm	331	Insert, fence mount
303	Scale, gauge	332	Fence
304	Fence, gauge	333	Rip fence head
305	Carriage bolt M6x40	334	Plastic shoes
306	Pan head screw M4x8	335	Sunk head screw M4x10
307	Hex nut M4	336	Allen screw M6x8
308	Mitre gauge rod	337	View lens, rip fence
309	Mitre gauge base	338	Rear clamp
310	Washer 6mm	339	Lock nut M6
311	Thumbnut M6	340	Spacer
312	Pan head screw M5x10	341	Bearing 80016
313	Indicator, gauge	342	Allen screw M6x35
314	Block, indicator	343	Rear plate, rip fence
315	Stop pin	344	Pin roll 5x16
316	Roller, gauge	345	Rear block, rip fence
320	Rear rail, table	346	Lock eccentric rod
321	Taping screw ST4.0x12	347	Lock eccentric
322	Left end cap, front rail	348	Rip fence lock rod
323	Front rail, table	349	Rip fence handle
324	Wing screw		
325	Right end cap, front rail		