

Edition : 1.0
Date: (09/24)

Instruction Manual

PNEUMATIC PLANISHING HAMMER PPH-70

Order Code: (S2277)

1.1 SPECIFICATIONS

Order Code	S2277
MODEL	PPH-70
Operation	Foot Pedal
Capacity (mm/gauge)	1.5/16 Mild Steel - 1.8/14 Aluminium
Throat (mm)	710mm
Speed (BPM)	1800 - 4600BPM
Operating Pressure PSI	50 to 100 (Maximum) PSI; 4 SCFM
Anvil Size (mm)	25, 50, 76, 158, 368, 914mm
Nett Weight	39kg

**WARNING**

Always check the capacity of the machine. Exceeding the capacity of the machine may result in sudden breakage that ejects dangerous metal debris at the operator or bystanders

**WARNING**

*Serious injury or death can result from using this machine **BEFORE** understanding its controls and related safety information. **DO NOT** operate, or allow others to operate, the machine until the information is understood.*

**WARNING**

It is impossible to cover all possible hazards Every workshop environment is different. These are designed as a guide to be used to compliment training and as a reminder to users prior to equipment use. Always consider safety first, as it applies to the individual working conditions.

1.2 IDENTIFICATION

Become familiar with the names and locations of the controls and features shown below to better understand the instructions when mentioned later in this manual.

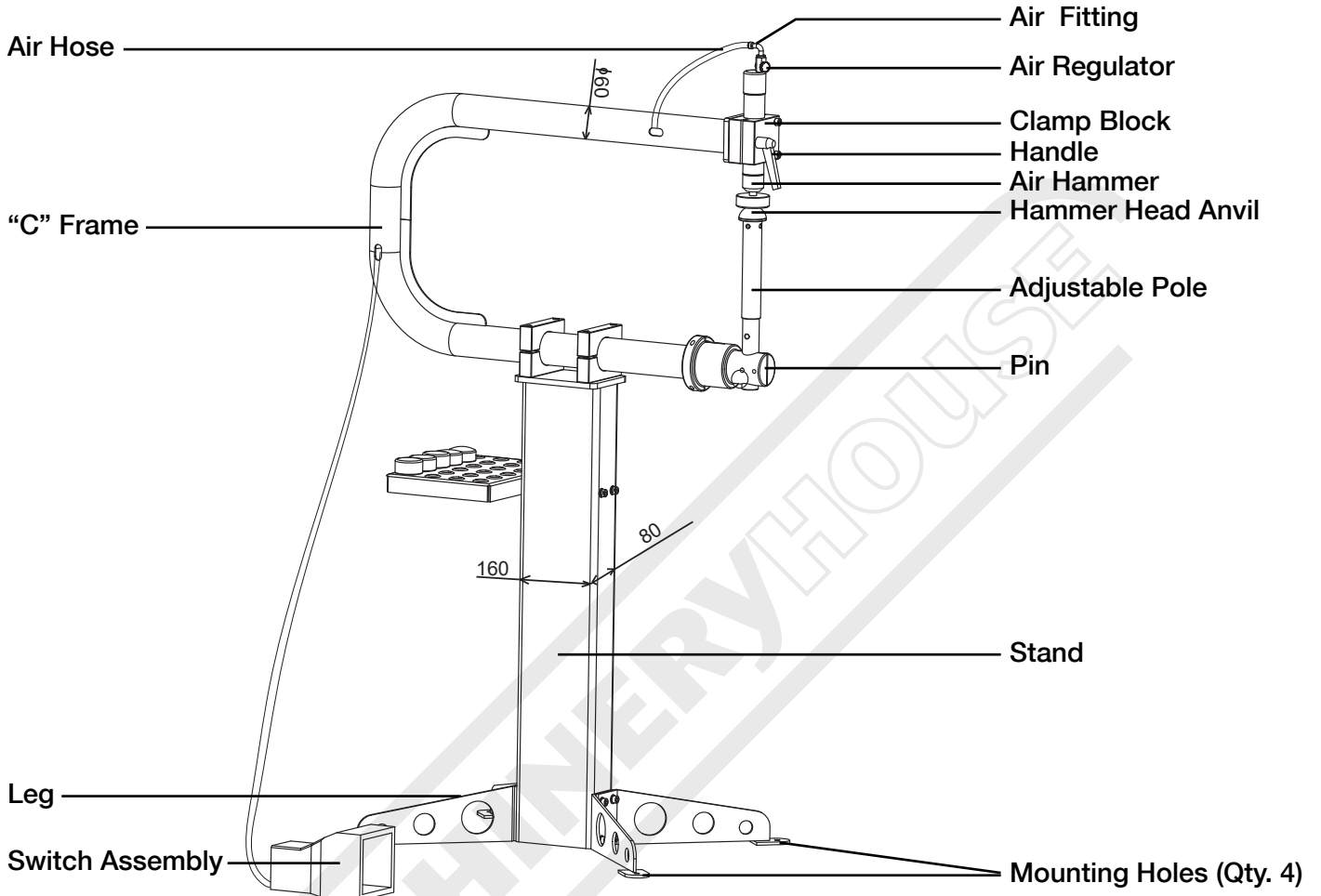

Anvils



Unpacking



When unpacking, check the packing list to make sure that all parts shown are included. If any parts are missing or broken, please contact your distributor.

1.3 ASSEMBLY DRAWING

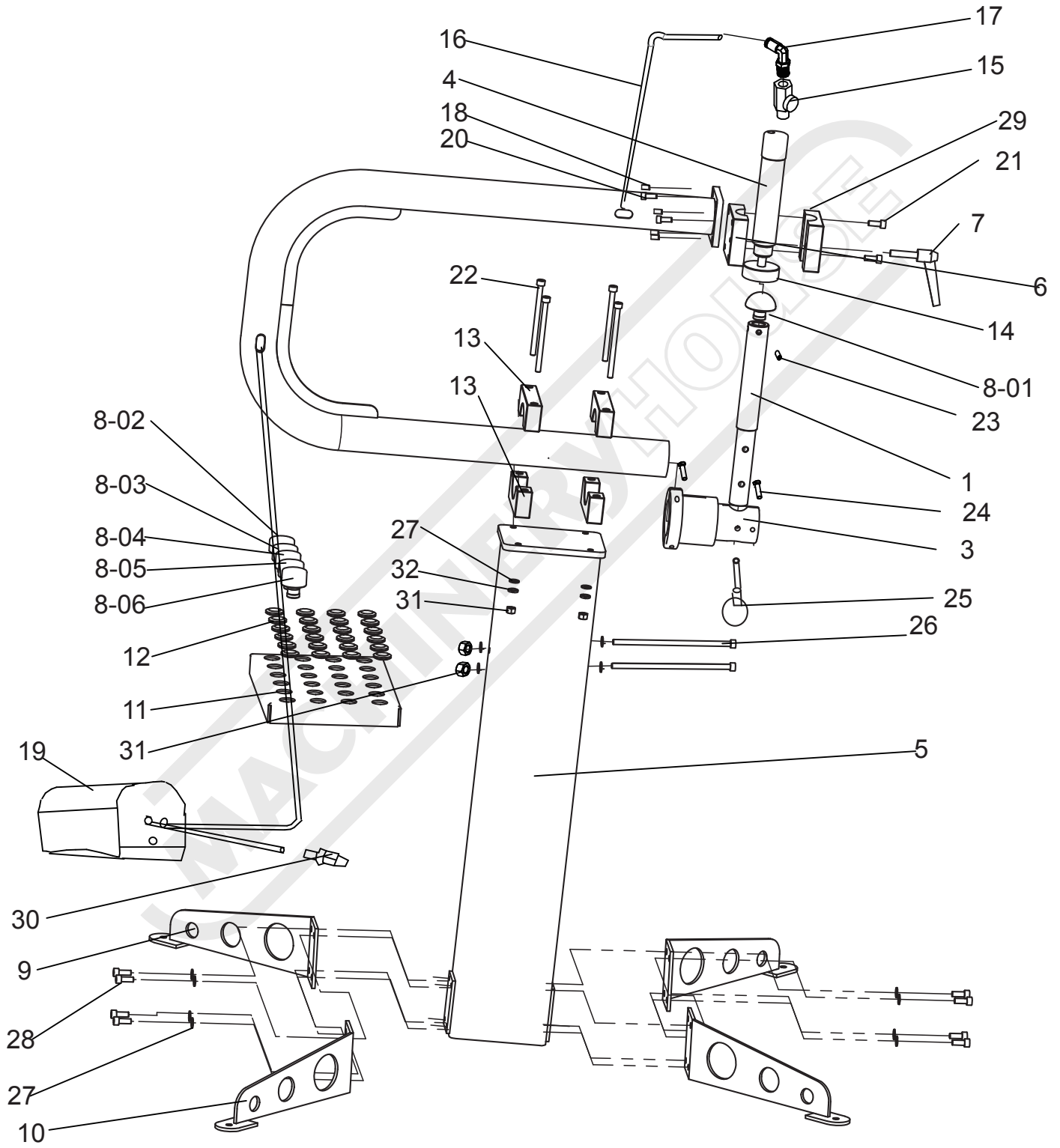

1.4 PARTS LIST

Part No.	Description	QTY
1	Adjustable Pole	1
2	"C" Frame	1
3	Connect Block	1
4	Pneumatic Hammer	1
5	Stand	1
6	Centre Clamp Block	1
7	Handle	1
8.01	1" Anvil (1R)	1
8.02	2" Anvil (2R)	1
8.03	3" Anvil (3R)	1
8.04	6.25" Anvil (6.25R)	1
8.05	14.5" Anvil (14.5R)	1
8.06	36" Anvil (36R)	1
9	Left Leg	2
10	Right Leg	2
11	Dies Rack	1
12	Rubber Ring	24
13	Clamp Block	4
14	Hammer Head	1

Part No.	Description	QTY
15	Regulator (Speed Control)	1
16	Air Hose	1
17	Air Fitting	1
18	Screw M8x8	4
19	Switch Assembly	1
20	Screw M8x20	4
21	Screw M8x40	2
22	Screw M8x120	4
23	Screw M8x8	4
24	Screw M8x25	2
25	Pin	1
26	Screw M8x180	2
27	Washer 8mm	16
28	Screw M8x20	8
29	Clamp Block	1
30	Quick Connector (male)	1
31	Nut M8	6
32	Spring Washer 8mm	4

1.5 ASSEMBLY

1. Attach 2 x Left Legs (#9) and 2 x Right Legs (#10) to Stand (#5) using screws (#28) and washers (#27)
2. Attach the Dies Rack (#11) to Stand (#5) using Screws (#26) and Nuts (#31)
3. Insert all Anvils (8.01-8.06) into Dies Rack (#11)
4. Attach C Frame (#2) to the top of Stand (#5) using the Clamp Block (#13) with 4 x Screws (#22), Washers (#27), Spring Washers (#32) and Nuts (#31).
5. Insert the Adjustable Pole (#1) into Connect Block (#3) and attach to the C Frame (#2) and lock in place using Pin (#25) and Screw (#24)
6. Insert a Anvil eg. (#8.01) into the Adjustable Pole (#1) and lock in place with Screws (#23)
7. Assemble the Pneumatic Hammer (#4) with Hammer Head (#14), Regulator (#15) & Air Fitting (#17) and attached to C Frame (#2) using Clamp Block (#29), Screws (#21), Handle (#7) and screws (#18 & 20).
8. Connect Air Hose (#16) to Air Fitting (#17)

1.6 AIR HAMMER - HEIGHT ADJUSTMENT

1. Loosen Handle.
2. Slide the Air Hammer body to desired height.
3. Re-tighten Handle.

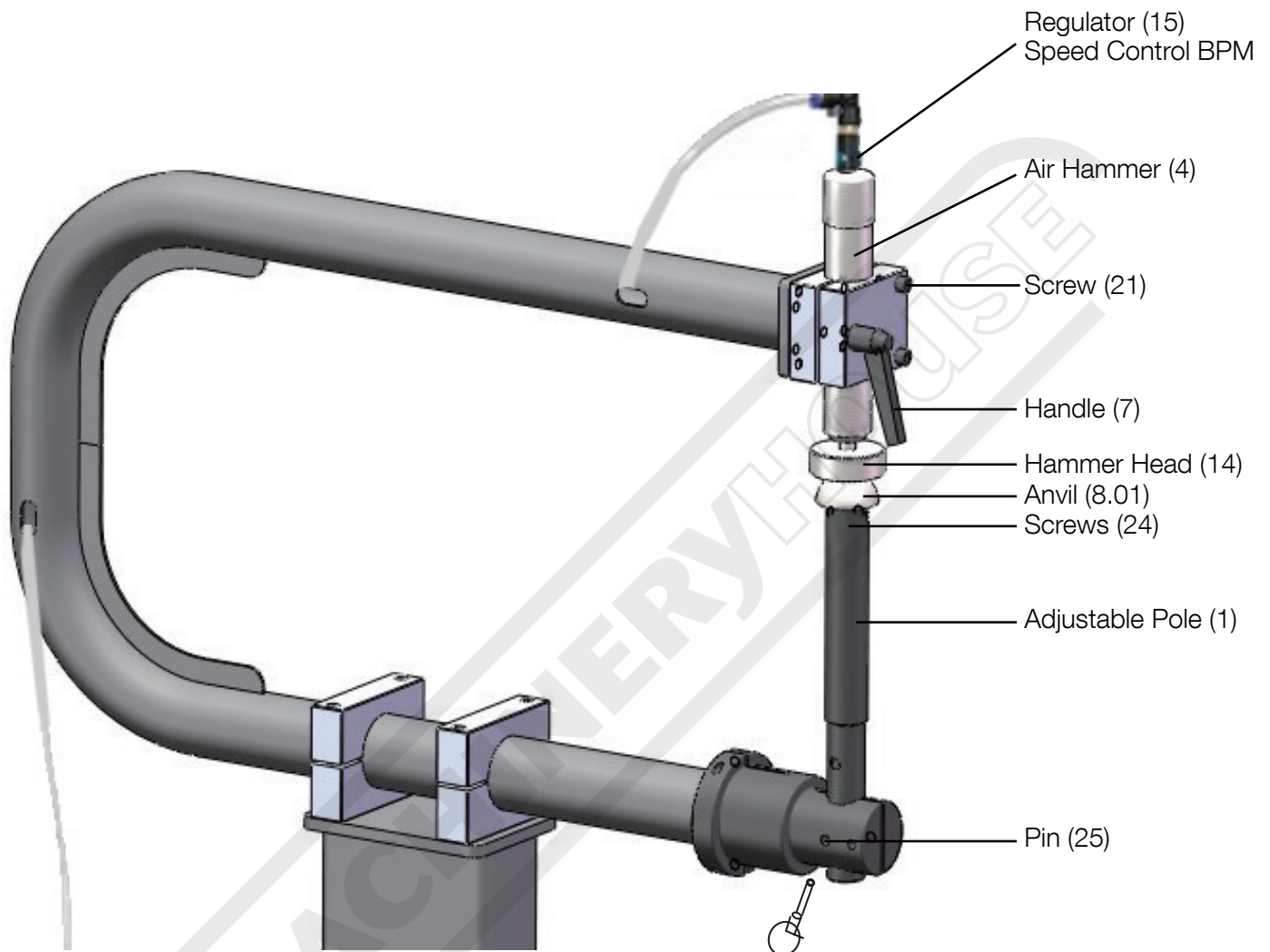

1.7 ADJUSTABLE POLE - HEIGHT ADJUSTMENT

1. Release Pin.
2. Slide the Air Hammer body to desired height.
3. Place Pin in hole to lock into place.

1.8 CHANGING ANVILS

1. Unscrew Screws (#24). Pull out Pin (#25), and move the Adjustable Pole (#1) down.
2. Replace Anvil with desired size onto the Adjustable Pole (1), Replace Pin (#25).
3. Re-tighten Screw (#24) completely
or loosen Handle (#7) slide Air Hammer Up to make room to replace Anvil.

1.9 AIR CONNECTION

1. Attach the Switch Assembly (#19) to your Air Hose from your Air Compressor (not supplied), then place Switch Assembly (#19) on the floor next to the Planishing Hammer.

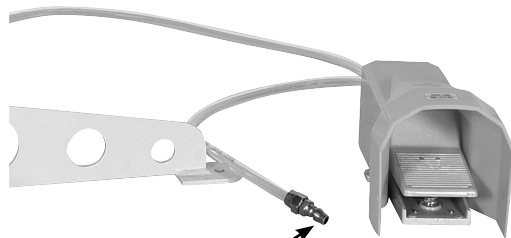

Connect Quick connect Fitting to Air Compressor
70PSI Air Pressure - (adjust to suit material)



CAUTION: Do not turn on the Air Compressor at this time.

Oiler and Filter Connection

Dirt, water, and the lack of pneumatic tool oil are major causes for tool wear. Install an optional oiler-filter (not supplied), as illustrated below for better performance.

Suggested to use following Filter & Lubricators:

- AFR-500 Filter Regulator (A270)
- AFR-500L In-line Lubricator (A271)
- Pneumatic Tool Oil (A037)



If the filter and oiler are not used, Always add a few drops of pneumatic tool oil through the air line before use.

2.0 OPERATION

1. Turn on the Air Compressor and set its regulator to 70 PSI. Regularly lubricate Air Lines with Air Tool Oil.
2. Before planishing, test the operation by pressing down on the foot Switch Assembly with your foot.
3. Adjust the lower Anvil adjustable pole (#1) to the correct height and set using the pin (#25).
4. Adjust the Hammer Head/Top Die down to meet the lower anvil leaving double the material thickness as clearance eg. if using 1.2mm thick material set the clearance to 2.4mm between upper and lower dies.
5. Spray some lubrication over working surface of material to save any sticktion.
6. Press down on the Switch Assembly on the floor with your foot to operate.
7. Adjust the speed (BRM) of the Air Hammer by turning the Regulator valve clockwise or counterclockwise.
8. Use both gloved hands to hold the material to be planished and place it between the Anvil and the Hammer Head.
9. When finished planishing, engage the foot pedal again and wait for the Air Hammer to stop completely.
10. Turn the Air Compressor off.
11. Press down on the Switch Assembly again to release any remain air pressure in the Air Hammer.

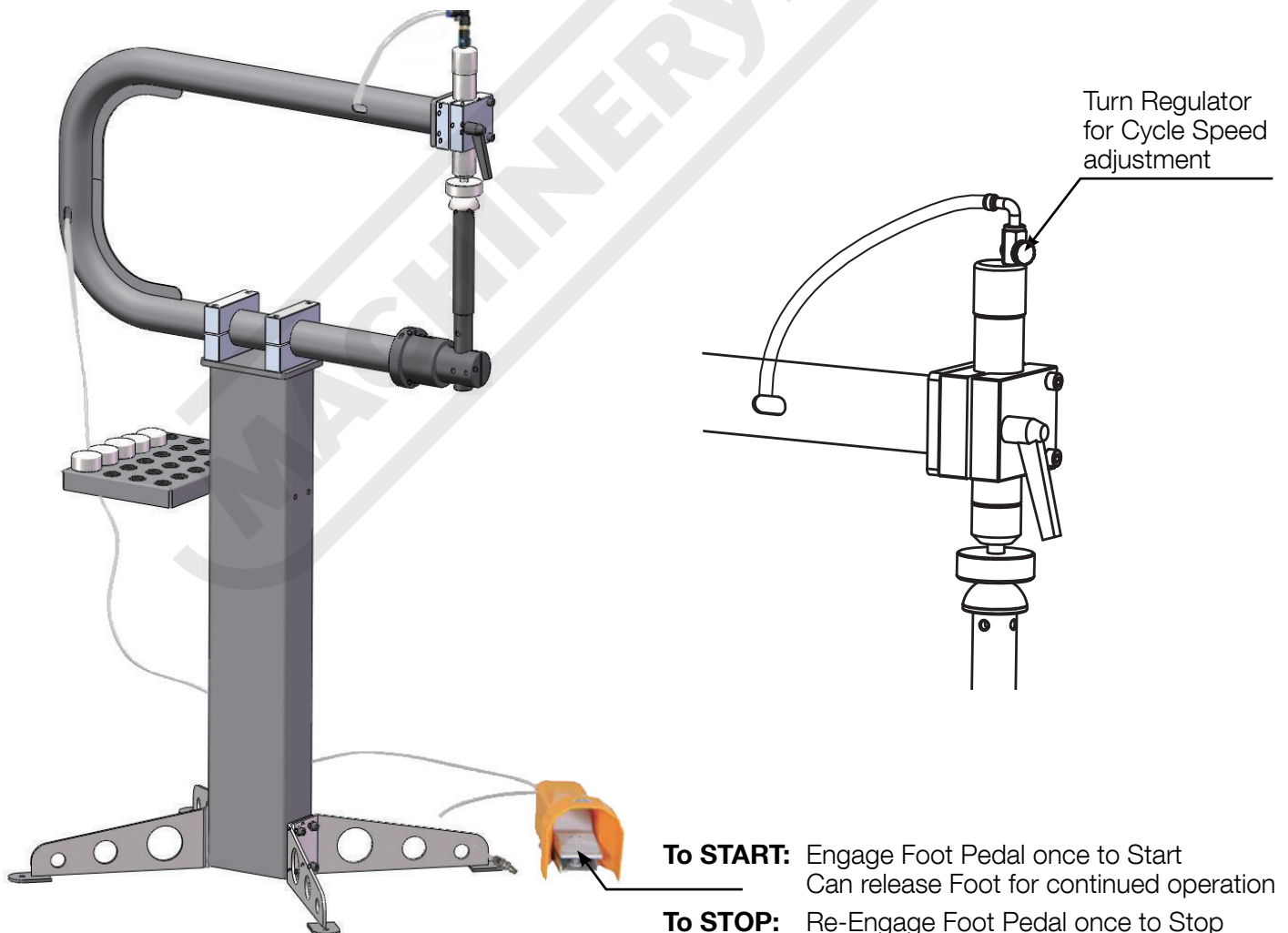

2.1 TROUBLESHOOTING

Problem	Probable Cause	Solution
Planishing Hammer does not operate when Switch pressed	No air pressure in air line	Check air line and compressor
Planishing Hammer operates at diminished pressure	Air pressure below normal operating pressure	Check regulator on compressor and Air Hammer

2.2 MAINTENANCE

1. After each use, wipe all components of the Planishing Hammer with a clean cloth to remove any dirt and grease buildup.
2. To maintain tool life, always lubricate the air line by adding a few drops of pneumatic tool oil to the air line (or Air Inlet) before each use. Or, install the automatic oiler-filter system as illustrated on page 7.
3. Before each use, drain water out of the air compressor tank and condensation from the air lines. Refer to the Air Compressor Operation Manual.
4. Cover the Planishing Hammer and keep in a clean and dry location.

WARNING

General Machinery Safety Instructions

Machinery House
requires you to read this entire Manual before using this machine.

- 1. Read the entire Manual before starting machinery.** Machinery may cause serious injury if not correctly used.
- 2. Always use correct hearing protection when operating machinery.** Machinery noise may cause permanent hearing damage.
- 3. Machinery must never be used when tired, or under the influence of drugs or alcohol.** When running machinery you must be alert at all times.
- 4. Wear correct Clothing.** At all times remove all loose clothing, necklaces, rings, jewelry, etc. Long hair must be contained in a hair net. Non-slip protective footwear must be worn.
- 5. Always wear correct respirators around fumes or dust when operating machinery.** Machinery fumes & dust can cause serious respiratory illness. Dust extractors must be used where applicable.
- 6. Always wear correct safety glasses.** When machining you must use the correct eye protection to prevent injuring your eyes.
- 7. Keep work clean and make sure you have good lighting.** Cluttered and dark shadows may cause accidents.
- 8. Personnel must be properly trained or well supervised when operating machinery.** Make sure you have clear and safe understanding of the machine you are operating.
- 9. Keep children and visitors away.** Make sure children and visitors are at a safe distance for you work area.
- 10. Keep your workshop childproof.** Use padlocks, Turn off master power switches and remove start switch keys.
- 11. Never leave machine unattended.** Turn power off and wait till machine has come to a complete stop before leaving the machine unattended.
- 12. Make a safe working environment.** Do not use machine in a damp, wet area, or where flammable or noxious fumes may exist.
- 13. Disconnect main power before service machine.** Make sure power switch is in the off position before re-connecting.
- 14. Use correct amperage extension cords.** Undersized extension cords overheat and lose power. Replace extension cords if they become damaged.
- 15. Keep machine well maintained.** Keep blades sharp and clean for best and safest performance. Follow instructions when lubricating and changing accessories.
- 16. Keep machine well guarded.** Make sure guards on machine are in place and are all working correctly.
- 17. Do not overreach.** Keep proper footing and balance at all times.
- 18. Secure workpiece.** Use clamps or a vice to hold the workpiece where practical. Keeping the workpiece secure will free up your hand to operate the machine and will protect hand from injury.
- 19. Check machine over before operating.** Check machine for damaged parts, loose bolts, Keys and wrenches left on machine and any other conditions that may effect the machines operation. Repair and replace damaged parts.
- 20. Use recommended accessories.** Refer to instruction manual or ask correct service officer when using accessories. The use of improper accessories may cause the risk of injury.
- 21. Do not force machinery.** Work at the speed and capacity at which the machine or accessory was designed.
- 22. Use correct lifting practice.** Always use the correct lifting methods when using machinery. Incorrect lifting methods can cause serious injury.
- 23. Lock mobile bases.** Make sure any mobile bases are locked before using machine.
- 24. Allergic reactions.** Certain metal shavings and cutting fluids may cause an allergic reaction in people and animals, especially when cutting as the fumes can be inhaled. Make sure you know what type of metal and cutting fluid you will be exposed to and how to avoid contamination.
- 25. Call for help.** If at any time you experience difficulties, stop the machine and call you nearest branch service department for help.

WARNING

Pneumatic Planishing Hammer Safety Instructions

Machinery House
requires you to read this entire Manual before using this machine.

- 1. Maintenance.** Make sure the Pneumatic Planishing Hammer is turned off and disconnect from the air before any inspection, adjustment or maintenance is carried out.
- 2. Pneumatic Planishing Hammer Condition.** Pneumatic Planishing Hammer must be maintained for a proper working condition. Never operate a Pneumatic Planishing Hammer that has damaged or worn parts. Scheduled routine maintenance should be performed on a scheduled basis.
- 3. Leaving a Pneumatic Planishing Hammer Unattended.** Always turn the Pneumatic Planishing Hammer off before leaving the Pneumatic Planishing Hammer. Do not leave Pneumatic Planishing Hammer running unattended for any reason.
- 4. Hand Hazard.** Keep hands and fingers clear from moving parts. Serious injury can occur if hand or finger tips get pinched between Air Hammer.
- 5. Gloves & Glasses.** Always wear leather gloves and approved safety glasses when using this machine.
- 6. Avoiding Entanglement.** Tie up long hair and use the correct hair nets to avoid any entanglement with moving parts.
- 7. Understand the machines controls.** Make sure you understand the use and operation of all controls.
- 8. Pneumatic Planishing Hammer kPa capacity.** Never use the Air Hammer over its rated PSI rating.
- 9. Hearing protection and hazards.** Always wear hearing protection as noise generated from Air Hammer and workpiece vibration can cause permanent hearing loss over time.
- 10. Eye protection.** Always wear safety glasses when using and cleaning this machine.
- 11. Work area hazards.** Keep the area around the Pneumatic Planishing Hammer clean from oil, tools, chips. Pay attention to other persons in the area and know what is going on around the area to ensure unintended accidents.
- 12. Level machine.** Level the machine on a flat concrete surface by using a spirit level.
- 13. Call for help.** If at any time you experience difficulties, stop the machine and call your nearest branch service department for help.

PLANT SAFETY PROGRAM

NEW MACHINERY HAZARD IDENTIFICATION, ASSESSMENT & CONTROL

Pneumatic Planishing Hammer

Developed in Co-operation Between A.W.I.S.A and Australia Chamber of Manufactures
 This program is based upon the Safe Work Australia, Code of Practice - Managing Risks of Plant in the Workplace (WHSA 2011 No10)

Item No.	Hazard Identification	Hazard Assessment	Risk Control Strategies <small>(Recommended for Purchase / Buyer / User)</small>
B	CRUSHING	LOW	Secure & support work material. Ensure machine is bolted down.
C	CUTTING, STABBING, PUNCTURING	MEDIUM	Wear gloves to prevent cuts from sharp material.
D	SHEARING	MEDIUM	Keep hands clear from moving parts.
F	STRIKING	LOW	Air hammer must be used with extreme precaution and in a controlled environment.
G	HIGH PRESSURE AIR	MEDIUM	Disconnect air supply to Air Hammer prior to checks or maintenance.
O	OTHER HAZARDS, NOISE, DUST.	HIGH MEDIUM	Hearing protection must be worn at all times. Safety gloves, shoes, pants must be worn. Make sure work area is clear from objects to save tripping.
Plant Safety Program to be read in conjunction with manufactures instructions			



www.machineryhouse.com.au



www.machineryhouse.co.nz

Authorised and signed by:

Safety officer:

Manager:

Revised Date: 12th March 2012



ENVIRONMENT PROTECTION

Recycle unwanted materials instead of disposing of them as waste. All tools, accessories and packaging should be sorted, taken to a recycling centre and disposed of in a manner which is compatible with the environment. When the product becomes completely unserviceable and requires disposal, drain any fluids (if applicable) into approved containers and dispose of the product and fluids according to local regulations.

Imported by

HARE & FORBES
MACHINERYHOUSE

Australian Distributor

Hare & Forbes
Machineryhouse
Sydney - Melbourne
Adelaide - Brisbane - Perth

Ph: 1300 202 200
www.machineryhouse.com.au

MACHINERYHOUSE

New Zealand Distributor

Machineryhouse
Auckland
Christchurch

Ph: 0800 142 326
www.machineryhouse.co.nz